

ELECTRICAL OPTIONS/ SPECIFICATIONS

OUTPUT	SUPPLY (NOM.)		
'A' 0.5 - 4.5V RATIO METRIC	5V		
SUPPLY CURRENT 12mA TYP. 20mA MAX.			
CONNECTIONS;	CABLE 3-CORE	CABLE 5-CORE	CONNECTOR
+Ve	RED	RED	:1
+ SENSE (5-WIRE ONLY)	-	ORANGE	:1
0V	BLACK	BLACK	:3
- SENSE (5-WIRE ONLY)	-	GREY	:3
OUTPUT	WHITE	WHITE	:2
BODY	SCREEN	SCREEN	:4

CABLE; 0.2mm², O/A SCREEN, PUR JACKET, SUPPLIED WITH 50cm OR REQUIRED LENGTH IN cm (15000cm MAX).
 STANDARD 3-CORE: BLACK Ø4mm JACKET e.g. L50
 OPTIONAL 5-CORE: BLUE Ø4.6mm JACKET e.g. LQ50
 CONNECTORS; MAXIMUM CONDUCTOR CROSS SECTION 0.25mm²

RANGE OF DISPLACEMENT FROM 0-51mm TO 0-100mm IN INCREMENTS OF 1mm e.g.76.
 BODY MATERIAL:- STAINLESS STEEL.
 FLANGE BASE MATERIAL:- STAINLESS STEEL (CODE 'N')

FURTHER OPTIONS:
 SINGLE PAIR OF BODY CLAMPS (CODE 'P')
 SPRUNG PLUNGER, TO EXTENDED POSITION (CODE 'R')
 DOME END* (CODE 'T') IN CONJUNCTION WITH SPRUNG PLUNGER (CODE 'R')
 PLUNGER FREE (CODE 'V') N.b. NOT AVAILABLE WITH SPRUNG OPTION.
 MAGNETIC TIP (CODE 'WA')

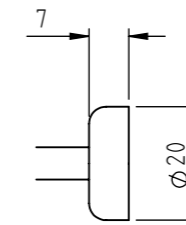

MAGNETIC TIP (CODE 'WA')

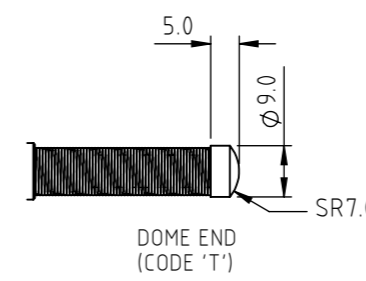
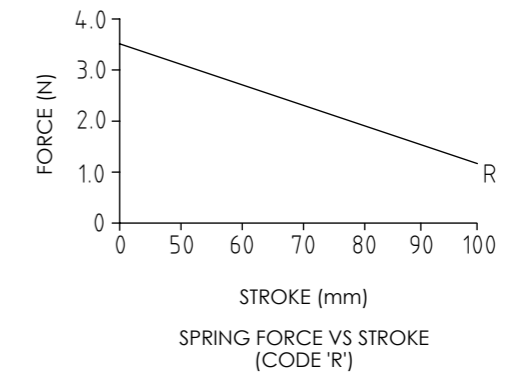

2 OFF 3.2 SLOTS ±15° ON 25.0 PCD

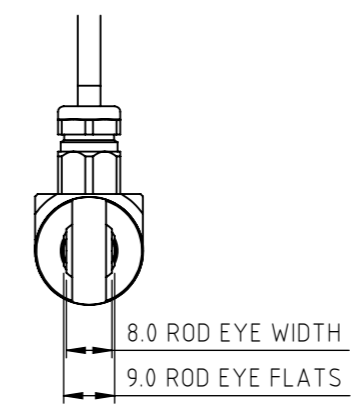
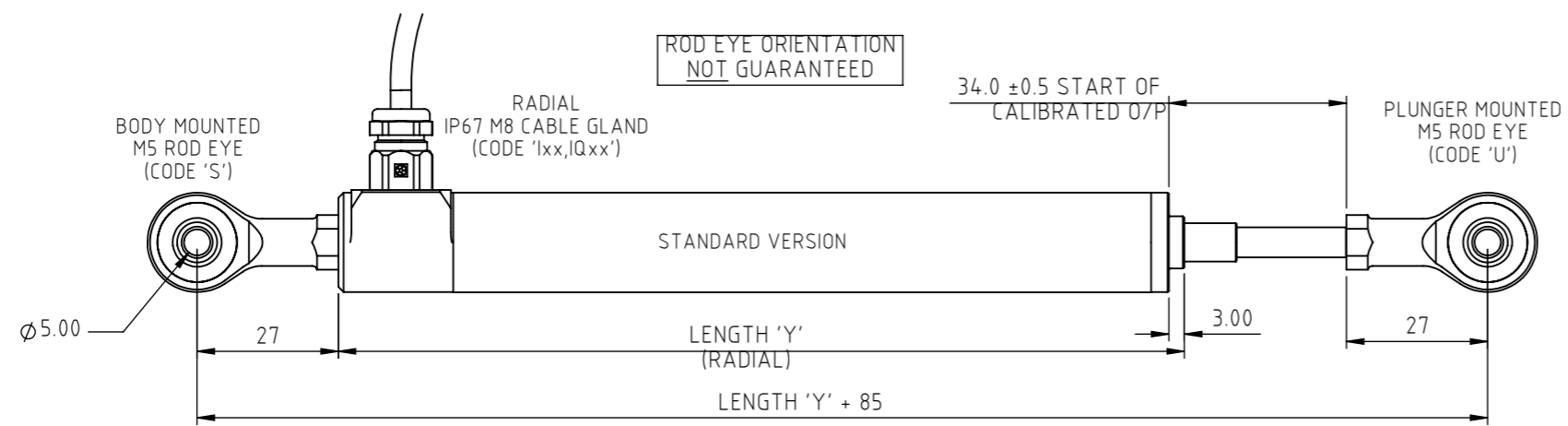
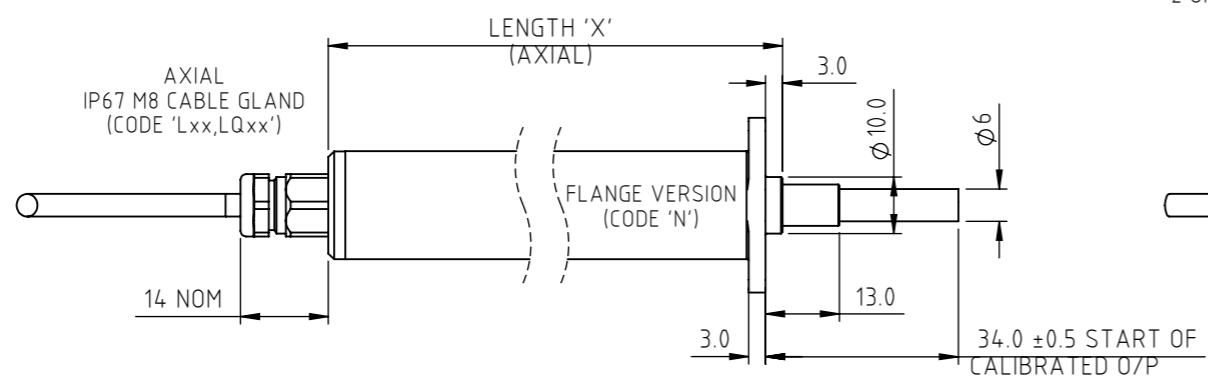
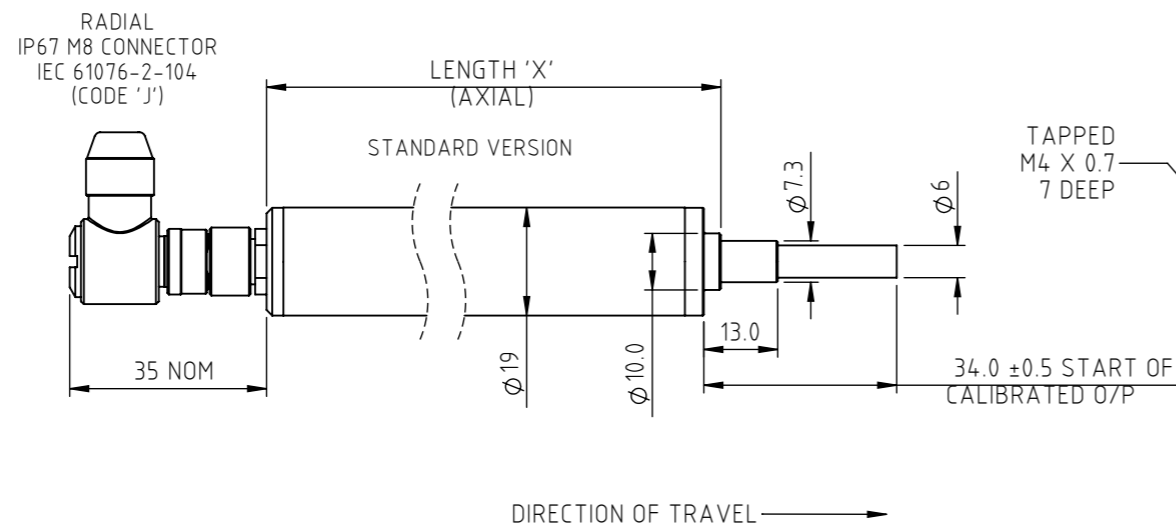
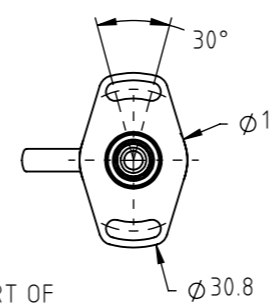

NOTE:- READ INSTALLATION SHEET M138-19 FOR FULL INSTRUCTIONS FOR USE.

ATEX / IECEx / UKEX APPROVED TO
Ex ia IIC T4 Ga (Ta= -40° to +80°C)
Ex ia IIIC T135°C Da (Ta= -40° to +80°C)
Ex ia I Ma (Ta= -40° to +80°C)
Ui 11.4V, li 0.2A, Pi 0.51W

APPROVED FOR USE IN CONJUNCTION WITH A GALVANICALLY ISOLATED BARRIER.

NOTE: APPROVAL ONLY APPLIES AT NORMAL ATMOSPHERIC PRESSURE!

DRAWINGS NOT TO BE CHANGED WITHOUT REFERENCE TO THE CHANGE PROCEDURE.
 CHANGES TO PARTS USED IN INTRINSICALLY SAFE PRODUCT MUST BE APPROVED BY THE AUTHORISED PERSON.
 THIS IS AN UNCONTROLLED PRINT AND WILL NOT BE UPDATED.

REV	CHANGE HISTORY	DR'WN	DATE	CHK'D
F	MAG TIP & RADIAL END CAP/ROD EYES RAN1311/1312	ASC	31/03/2021	PDM

NOTE: SENSORS WITH TRAVEL UP TO 50mm ARE MADE IN STANDARD LENGTHS

BODY LENGTH (mm)		TRAVEL (mm)	
CALIBRATED	MECHANICAL	'X' AXIAL	'Y' RADIAL
0-51 TO 0-70	70	143.0	162.0
0-71 TO 0-100	100	173.0	192.0

THE PLUNGER RETRACTS 8mm FROM START OF CALIBRATED TRAVEL (2mm FOR SPRUNG VERSIONS) AND EXTENDS 11mm* BEYOND END OF MECHANICAL TRAVEL.
 *DOES NOT INCLUDE DIFFERENCE BETWEEN CALIBRATED AND MECHANICAL TRAVEL.
 DIMENSIONS ARE NOMINAL.
 'V' CODED PLUNGER WILL DEPART SENSOR BODY.



APPROVED BY	REV		X	±0.4
RDM	F		X.X	±0.2
DESCRIPTION		M138 INTRINSICALLY SAFE MID STROKE SLIM-LINE LINEAR POSITION SENSOR		
SCALE	3:4	DRAWING NUMBER		
A3		M138-11		SHEET 1 OF 1



M138 MID STROKE SLIM-LINE LINEAR POSITION SENSOR INTRINSICALLY SAFE FOR HAZARDOUS MINING ENVIRONMENTS

- **Intrinsically safe for Mining to:
Ex I/II M1/1GD**
- **Non-contacting inductive technology to
eliminate wear**
- **Travel set to customer's requirement**
- **Compact 19 mm diameter body**
- **High durability and reliability**
- **High accuracy and stability**
- **Sealing to IP67**

As a leading designer and manufacturer of linear, rotary, tilt and intrinsically safe position sensors, Positek® has the expertise to supply a sensor to suit a wide variety of applications.

Our intrinsically safe M138 incorporates electronics system EX07 which is ATEX / IECEx / UKEX approved for use in potentially explosive **gas/vapour** and **dust** atmospheres and **mining** environments.

The M138 is designed for a wide range of industrial applications and is ideal for OEMs seeking good sensor performance in situations where a small diameter, short-bodied sensor is required for operation in hazardous areas. The unit is compact and space-efficient, being responsive along almost its entire length, and like all Positek® sensors provides a linear output proportional to travel. Each unit is supplied with the output calibrated to the travel required by the customer, from 51 to 100mm and with full EMC protection built in.

Overall performance, repeatability and stability are outstanding over a wide temperature range.

The sensor has a compact 19 mm diameter stainless steel body, is easy to install and set up. Mounting options include flange, M5 rod eye bearings and body clamps. The plunger can be supplied free or captive, with a female M4 thread, an M5 rod eye, magnetic tip, or spring-loaded with a dome end. The M138 also offers a range of mechanical options, environmental sealing is to IP67.



SPECIFICATION

Dimensions

Body diameter: 19 mm
Body length dependant on selected calibrated travel, cable/connector orientation and mounting option:

Body Length (Axial version):		
Calibrated Travel	Standard	Flange mounted
51 mm to 70 mm	137.5 mm	143 mm
71 mm to 100 mm	167.5 mm	173 mm

Body Length (Radial version):		
Calibrated Travel	Standard	Flange mounted
51 mm to 70 mm	156.5mm	162 mm
71 mm to 100 mm	186.5 mm	192 mm

Plunger: Ø 6mm

For full mechanical details see drawing M138-11

Power Supply +5V dc nom. ± 0.5V, 10mA typ 20mA max

Output Signal 0.5-4.5V dc ratiometric, Load: 5kΩ min.

Independent Linearity ≤ ± 0.25% FSO @ 20°C

≤ ± 0.1% FSO @ 20°C available upon request.

Temperature Coefficients < ± 0.01%/°C Gain &

< ± 0.01%FS/°C Offset

> 10 kHz (-3dB)

Frequency Response Infinite

Resolution < 0.02% FSO

Noise Ex I/II M1/GD

Intrinsic Safety Ex ia IIC T4 Ga (Ta= -40 to 80°C)

Ex ia IIIC T135°C Da (Ta= -40 to 80°C)

Ex ia I Ma (Ta=-40 to 80°C)

Approval only applies to the specified ambient temperature range and atmospheric conditions in the range 0.80 to 1.10 Bar, oxygen ≤ 21%

Sensor Input Parameters Ui: 11.4V, Ii: 0.20A, Pi: 0.51W.

(without cable) Ci: 1.16µF, Li: 50µH

(with cable) Ci: 1.36µF, Li: 860µH with 1km max. cable

Environmental Temperature Limits

Operating -40°C to +80°C

Storage -40°C to +125°C

Sealing IP67

EMC Performance EN 61000-6-2, EN 61000-6-3

Vibration IEC 68-2-6: 10 g

Shock IEC 68-2-29: 40 g

MTBF 350,000 hrs 40°C Gf

Drawing List

M138-11 Sensor Outline

Drawings, in AutoCAD® dwg or dxf format, available on request.



For further information please contact:

www.positek.com sales@positek.com

Tel: +44(0)1242 820027 fax: +44(0)1242 820615

Positek, Andoversford Industrial Estate, Cheltenham GL54 4LB. U.K.

M138-17f

1 of 3



M138 MID STROKE SLIM-LINE LINEAR POSITION SENSOR INTRINSICALLY SAFE FOR HAZARDOUS MINING ENVIRONMENTS

Intrinsically safe equipment is defined as "equipment which is incapable of releasing sufficient electrical or thermal energy under normal or abnormal conditions to cause ignition of a specific hazardous atmosphere mixture in its most easily ignited concentration."

ATEX / IECEx / UKEX approved to;
Ex I/II M1/GD
Ex ia IIC T4 Ga (Ta= -40°C to 80°C)
Ex ia IIIC T135°C Da (Ta= -40°C to 80°C)
Ex ia I Ma (Ta=-40°C to 80°C)

Designates the sensor as belonging to; Groups I and II: suitable for all areas (**including mining**), Category M1/1 GD: can be used in areas with continuous, long or frequent periods of exposure to hazardous gas (Zones 2 to 0) and dust (Zone 20), equipment remains energised.

Gas / Vapour:

Protection class ia, denotes intrinsically safe for all zones Apparatus group IIC: suitable for IIA, IIB and IIC explosive gas / vapour.

Temperature class T4: maximum surface temperature under fault conditions 135°C.

Dust:

T135°C: maximum surface temperature under fault conditions.

Ambient temperature range extended to -40°C to +80°C.

It is imperative Positek® intrinsically safe sensors be used in conjunction with a galvanic barrier to meet the requirements of the product certification. The Positek X005 Galvanic Isolation Amplifier is purpose made for Positek IS sensors making it the perfect choice. Refer to the X005 datasheet for product specification and output configuration options.

Safety Parameters:-

Uj: 11.4V, Ii: 0.20A, Pi: 0.51W
Ci = 1.36µF* Li = 860µH* (cable option/s)
Ci = 1.16µF Li = 50µH (connector option/s)

*Figures for 1km cable where: Ci = 200pF/m & Li = 810nH/m

Sensors can be installed with a maximum of 1000m of cable.

Cable characteristics must not exceed:-

Capacitance: ≤ 200 pF/m for max. total of: 200 nF.
Inductance: ≤ 810 nH/m for max. total of: 810 µH.

For cable lengths exceeding 10 metres a five wire connection is recommended to eliminate errors introduced by cable resistance and associated temperature coefficients.

ATEX / IECEx / UKEX approved sensors suitable for gas (X series) and dust (E series) applications, are also available from Positek.P

TABLE OF OPTIONS

CALIBRATED TRAVEL: Factory set to any length from 0-51mm to 0-100mm (e.g. 76mm).

ELECTRICAL INTERFACE OPTIONS

The Positek® X005 Galvanic Isolation Amplifier is available with the following output options;

Standard: 0.5 - 9.5V or 4 - 20mA.
Reverse: 9.5 - 0.5V or 20 - 4mA.

CONNECTOR/CABLE OPTIONS

Connector - 4-pole M8 IEC 61076-2-104 Axial/Radial IP67
Cable[†] with M8 gland Axial/Radial IP67

Three core (black jacket) or five core (blue jacket) cable options available.
Cable length >50 cm – please specify length in cm up to 15000 cm max.
We recommend all customers refer to the 3 or 5-Wire Mode Connection page.

MOUNTING OPTIONS

Flange, Body Tube Clamp (axial or radial versions),
M5 rod eye bearings (radial versions only).

PUSH ROD OPTIONS – Retained[†] or Free with M4x0.7 female thread, M5 rod eye bearing or Magnetic tip, Spring loaded with or without[#] Dome end.

[†] standard, retained with female thread.

[#] spring supplied loose.

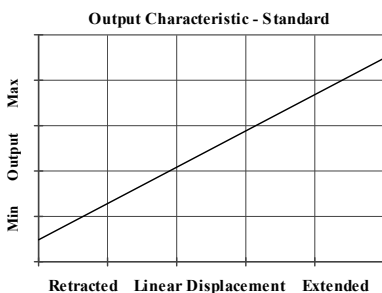

For further information please contact:

www.positek.com sales@positek.com

Tel: +44(0)1242 820027 fax: +44(0)1242 820615

Positek, Andoversford Industrial Estate, Cheltenham GL54 4LB. U.K.



Three or Five-Wire Mode Connection

FOR INTRINSICALLY SAFE SENSORS IN HAZARDOUS ATMOSPHERES

The aim of this document is to help readers who do not understand what is meant by three or five wire modes of connection between the galvanic isolation amplifier and sensor, and the factors behind them. It is by no means an in-depth technical analysis of the subject.

Whether opting for a pre-wired Positek® Intrinsically Safe sensor or one with a connector, choosing the right mode of connection and cable to suit the application requires careful consideration.

Interconnecting cables are not perfect conductors and offer resistance to current flow, the magnitude of resistance[†] depends on conductors resistivity, which changes with temperature, cross sectional area[‡] and length. If the voltage were to be measured at both ends of a length of wire it would be found they are different, this is known as volts drop. Volts drop changes with current flow and can be calculated using Ohm's law, it should be noted that volts drop occurs in both positive and negative conductors. The effects of volts drop can be reduced by increasing the conductors cross sectional area, this does not however eliminate the effects due to temperature variation. There are instances where large cross-section cables are not practical; for example most standard industrial connectors of the type used for sensors have a maximum conductor capacity of 0.75mm², copper prices and ease of installation are other considerations.

This is important because the effects of volts drop can significantly alter the perceived accuracy of the sensor which is ratiometric i.e. the output signal is directly affected by the voltage across the sensor. Changes in temperature will also be seen as gain variation in the sensor output.

Three wire mode connections are common and are suitable in most cases with short or moderate cable runs. Applications that do not require a high degree of accuracy but have cable runs, say in excess of 10m, volts drop can be reduced by introducing a terminal box close to the sensor and using a larger cross-section cable for a majority of the cable run. Sensors supplied with three core cable are calibrated with the cable fitted which largely eliminates errors due to conductor resistance at room temperature however, as mentioned above, small gain errors due to temperature fluctuations should be expected.

Five wire mode connections have significant benefits as losses in the positive and negative conductors are compensated for by the galvanic isolation amplifier which can 'sense' the voltage across the sensor and dynamically adjust the output voltage so that the voltage across the sensor is correct. The effects of cable resistance and associated temperature coefficients are eliminated allowing for smaller conductors than a three wire connection for the same cable run. The amplifier can compensate for up to 15Ω per conductor with a current flow of 15mA, which is more than adequate for 150m of 0.25 mm² cable, longer lengths will require larger conductors.

For this reason Positek® recommends five wire connections for cable lengths exceeding 10 metres in 0.25 mm² cable to preserve the full accuracy of the sensor.

See illustrations below for examples of connecting a sensor to the galvanic isolation amplifier.

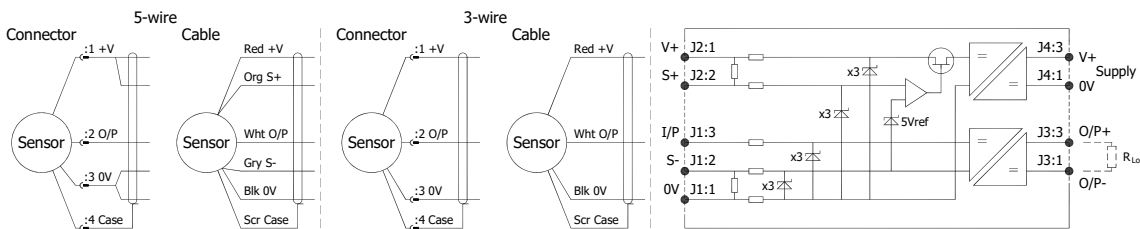

Cable Length (metres)	Up to 150	150 - 300	300 - 450	450 - 600	600 - 900	900 - 1000
Cross Section (mm ²)	0.25	0.5	0.75	1.0	1.5	2.0

The table above shows recommended conductor sizes with respect to cable length for both three and five wire connections, based on copper conductors. Three wire connections will introduce a gain reduction of 5% and a ±1% temperature dependence of gain over the range -40°C to +80°C for the cable temperature. (i.e. about -150 ppm/°C for the maximum lengths shown and less pro rata for shorter lengths.)

It should be noted that the maximum cable length, as specified in the sensor certification, takes **precedence** and **must not** be exceeded.

Positek® sensors are supplied with three core 0.25 mm² cable as standard, however five core 0.25 mm² cable can be supplied on request. The galvanic isolation amplifier is available as;

G005-*** for 'G' and 'H' prefix sensors
X005-*** for 'E', 'M' and 'X' prefix sensors

[†] $R = \rho L/A$ ρ is the resistivity of the conductor (Ωm) L is the length of conductor (m) A is the conductor cross-sectional area (m²).

[‡] It is presumed that direct current flow is uniform across the cross-section of the wire, the galvanic isolation amplifier and sensor are a dc system.



For further information please contact:

www.positek.com sales@positek.com

Tel: +44(0)1242 820027 fax: +44(0)1242 820615

Positek, Andoversford Industrial Estate, Cheltenham GL54 4LB. U.K.

Intrinsically Safe - Mining Environments

M138 Mid Stroke Slim-Line Position Sensor

a	b	c	d	e	f	g	h	j	
M138	Displacement	A	Connections	Option	Option	Option	Option	Option	Z-code

a Displacement (mm)		Value
Displacement in mm	e.g. 0 - 66 mm	66
b Output		
Supply V dc V _s (tolerance)	Output	Code
+5V (4.5 - 5.5V)	0.5 - 4.5V (ratiometric with supply)	A
c Connections Cable or Connector		Code
Cable Gland - Radial	IP67 metal - 3-core cable	Ixx
	IP67 metal - 5-core cable	IQxx
Connector - Axial	IP67 M8 IEC 60176-2-104 metal	J
	pre-wired - 3-core cable	Jxx
Connector - Radial	IP67 M8 IEC 60176-2-104 metal	K
	pre-wired - 3-core cable	Kxx
Cable Gland - Axial	IP67 metal - 3-core cable	Lxx
	IP67 metal - 5-core cable	LQxx
Specify required cable length 'xx' in cm. e.g. L2000 specifies cable gland with 20 m of cable, 50 cm supplied as standard. N.b.! M8 connector option with 5-core cable not available.		
d Housing		Code
Standard - default		blank
Flange Mount		N
M5 Rod-eye Bearing	Radial body style only	S
e Body Fittings		Code
None - default		blank
Body Clamps - 1 pair		P
f Sprung Plunger		Code
None - default		blank
Spring Extend	Captive plunger only.	R
g Plunger Fittings		Code
None - default	Female Thread M4x0.7x7 deep	blank
Dome end	Requires option 'R'	T
M5 Rod-eye Bearing		U
Magnetic Tip		WA
h Plunger Options		Code
Captive - default	Plunger is retained	blank
Non-captive	Plunger can depart body	V
j Z-code		Code
Calibration to suit X005 - Default		Z000
≤± 0.1% @20°C Independent Linearity displacement between 10mm & 50mm only!		Z650

Note!

All Intrinsically Safe (IS) sensors must have a Z-code suffix.

IS sensors must be used in conjunction with a Galvanic Isolation Amplifier - See X005 for Output options.



Installation Information

M138 MID STROKE SLIM-LINE LINEAR POSITION SENSOR

INTRINSICALLY SAFE FOR HAZARDOUS MINING ENVIRONMENTS

ATEX / IECEx / UKEX Qualified to Intrinsic Safety Standard Certificate numbers SIRA 13ATEX2371X IECEX SIR 13.0154X CSAE 21UKEX2537X		Ex I/II M1/1GD Ex ia IIC T4 Ga (Ta = -40°C to +80°C) Ex ia IIIC T135°C Da (Ta = -40°C to +80°C) Ex ia I Ma (Ta = -40 to +80°C)	
Electronics Version	Output Description:	Supply Voltage: <small>V_s (tolerance)</small>	Load resistance:
EX07	0.5 - 4.5V (ratiometric with supply) <small>[Output code 'A']</small>	+5V (4.5 - 5.5V)	5kΩ min

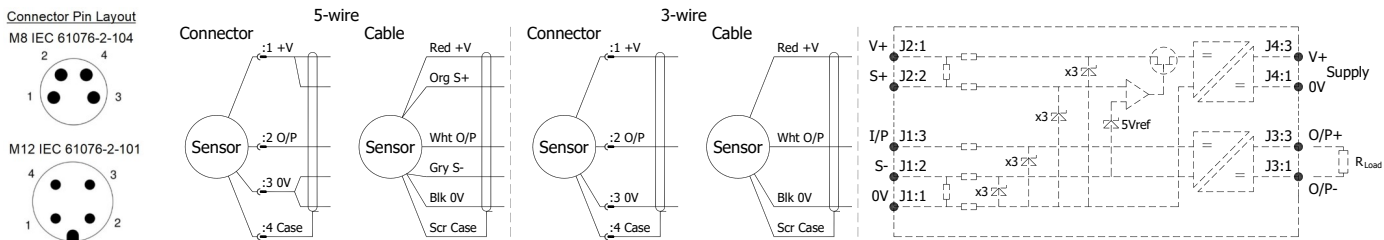

Putting Into Service: The sensor must be used with a galvanic isolation barrier designed to supply the sensor with a nominal 5V and to transmit the sensor output to a safe area. The barrier parameters must not exceed:-

U_i = 11.4V **I_i = 0.20A** **P_i = 0.51W**
C_i = 1.36μF* **L_i = 860μH*** (Options: IAxx, IAQxx, IBxx, IBQxx, Lxx, LQxx) *Figures for 1km cable
C_i = 1.16μF **L_i = 50μH** (Options: J, K)

The sensor is certified to be used with up to **1000m** of cable, cable characteristics must not exceed:-

Capacitance: ≤ 200 pF/m or max. total of: 200 nF
 Inductance: ≤ 810 nH/m or max. total of: 810 μH

Approval only applies to specified ambient temperature range and atmospheric conditions in the range: 0.80 to 1.10 Bar, oxygen ≤ 21%.

The performance of the sensor may be affected by voltage drops associated with long cable lengths; For cable lengths exceeding 10 metres a five wire connection is recommended to eliminate errors introduced by cable resistance and associated temperature coefficients.

Special Condition for Safe Use:

The apparatus does not meet the 500 V r.m.s dielectric strength test between circuit and frame, in accordance with clause 6.3.13 of IEC 60079-11:2011. This must be taken into consideration on installation.

When using a Sensor that has an integral cable in a dust application, the free end of the cable shall be appropriately terminated for the zone of use.

Under certain extreme circumstances, the non-metallic and isolated metal parts incorporated in the enclosure of this equipment may generate an ignition-capable level of electrostatic charge. Therefore the equipment shall not be installed in a location where the external conditions are conducive to the build-up of electrostatic charge on such surfaces. This is particularly important if the equipment is installed in a zone 0 location. In addition, the equipment shall only be cleaned with a damp cloth.

Use: The sensor is designed to measure linear displacement and provide an analogue output signal.

Assembly and Dismantling: The unit is not to be serviced or dismantled and re-assembled by the user.

Maintenance: No maintenance is required.

Mechanical Mounting Options: Depending on options, body can be mounted by flange, rod eye bearings or clamping the sensor body - body clamps are available, if not already ordered. Plunger mounted by M4x0.7 female thread, rod-eye bearing or magnetic tip.

Output Characteristic: Plunger extended 34.5 mm* from mounting face at start of normal travel. *Note: where dome end option is fitted add 5 mm. The output increases as the plunger extends from the sensor body, the calibrated stroke is between 51 mm and 100 mm.

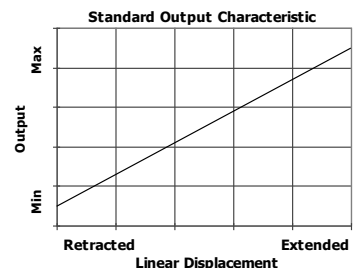

Incorrect Connection Protection levels: Not protected – the sensor is **not** protected against either reverse polarity or over-voltage. The risk of damage should be minimal where the supply current is limited to less than 50mA.



For further information please contact:
www.positek.com sales@positek.com
 Tel: +44(0)1242 820027 fax: +44(0)1242 820615
 Positek, Andoversford Industrial Estate, Cheltenham GL54 4LB. U.K.